

PARTIAL DISCHARGE DETECTION BY TEV SENSORS AND SIGNAL PROPAGATION ANALYSIS IN TRANSFORMER MODEL

Akihiko Itose^{1*}, Yuki Tai¹, Masahiro Kozako¹, Masayuki Hikita¹

¹Kyushu Institute of technology, Kitakyushu, Japan

*Email: <k108012a@mail.kyutech.jp>

Abstract: This paper deals with a detailed study on partial discharge (PD) generated in transformers using transient earth voltage (TEV) detection method. Experiment and numerical analysis are carried out using an iron box model which simulates a tank of an actual transformer. In the test model, propagation properties of TEV signal caused by PD occurring inside and outside of the transformer model are examined. Results reveal that the electromagnetic waves generated by PD in the model can leak from the opening window, having special frequency determined by the size of the opening window. It is also found that TEV sensor placed on the surface of the tank detects a TEV signal originating from the leaked electromagnetic wave. On the other hand, TEV signal by electromagnetic waves generated by an external PD source is found to have a wider frequency band than that by leaked electromagnetic wave. In addition, electromagnetic field and surface current analysis are performed using finite difference time domain (FDTD) method and simulated results are compared with experimental ones. As a result, it is shown that leaked electromagnetic wave excites a surface current on the outer tank wall of the transformer model. It is also found that there exists difference in the time required for TEV signal to arrive at the inside and outside sensors. The results indicate that PD emitting electromagnetic waves leaked from the dielectric discontinuities can be detected by the TEV method. Furthermore, these results suggest a combination of the detected waveform and its frequency band could lead to highly reliable diagnosis of the apparatus by TEV detection method.

1 INTRODUCTION

In general, small-amplitude abnormal discharges can occur locally in high voltage electric power equipment, namely, partial discharges (PD) as pre-breakdown phenomena. Partial discharge obtained by a variety of techniques is an index of diagnosis of the equipment. Application of PD detection technology to condition monitoring and diagnosis of electrical insulation in the equipment has grown drastically. The technology has been widely accepted for many kinds of electric power apparatus. A coupling capacitor method has been widely applied as a conventional measurement method. Since, these methods must be conducted temporarily off-line, there are not well suited to online PD measurement. So, easier installation of the measuring system is required. Since TEV detection sensor is non-intrusive sensor, it can be placed on the outside surface of a metal tank and wall. So, the TEV method is suitable for on-line insulation diagnosis and has the potential to be widely employed in practical applications. While TEV method has been put into practical use in some apparatus, there remain issues regarding the propagation path and detection principle of transient earth voltage (TEV) signal for electric power equipment. Luo et al have studied PD detection and analysis based on the TEV principle, formulated TEV signal and compared analysed results with measured ones. In the mathematical derivation, various losses due to surface

impedance is ignored [1]. Although Li et al also discuss on TEV detection method of the study on the actual equipment has not been made [2]. Characteristics of TEV-based PD and pulse recognition methods are rarely discussed.

From these points of view, this paper deals with PD characteristics occurring in the power equipment by TEV method using a transformer model tank. Electromagnetic field and surface current analysis are also performed using FDTD method to demonstrate the usefulness of TEV method.

2 PRINCIPLE OF TRANSIENT EARTH VOLTAGE (TEV) METHOD

Figure 1 illustrates mechanism of generation and detection of TEV for PD occurring in a metal wall. When PD occurs in power equipment such as a transformer, electromagnetic (EM) waves are emitted. The EM waves escape from dielectric discontinuities (joint, isolated area, bushing, etc.) in the metal tank of the transformer and then propagate on the external surface of the metal tank wall. Then, the surface current generated by EM waves is excited, and flows to the ground. Such propagating electromagnetic waves can be obtained by capacitive sensor and recorded as TEV signals [2, 3].

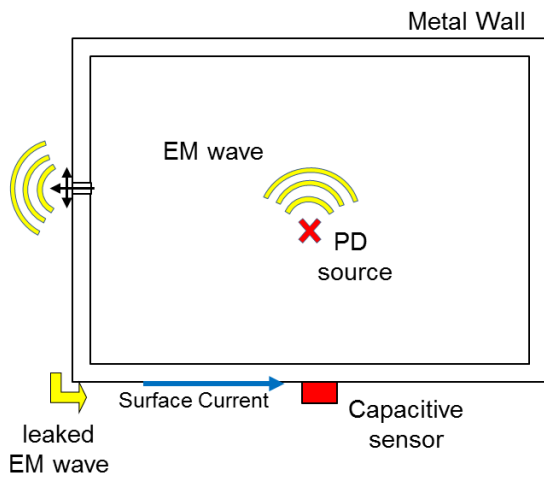

Figure 1: Mechanism of generation and detection of transient earth voltage (TEV)

3 EXPERIMENTAL SET UP

Experiments of PD detection were conducted to investigate transient earth voltage signal propagation in a model transformer tank.

Figures 2 and 3 show experimental circuit for a PD source located inside and outside of a model transformer tank, respectively. The electrode used in this experiment consists of a rod electrode with tip diameter of 1 mm and plane electrode of 50 mm in diameter made by brass. PD inception voltage (PDIV) of the electrode system was 1.6 kV. Then, AC voltage 2.0kV was applied to the electrode to generate PD of the charge of the order of 500 pC. The metal tank was made of iron with the thickness of 5mm and the size 500 mm × 500 mm × 500 mm, and had a bushing in the upper part of the tank wall. One of the side walls of the cubic tank can be opened. Two TEV sensors (HVPD: CC-SG1, 1 – 50 MHz) were attached on the inner and outer surface of the tank wall. HFCT (ETS-LINDGRN: 94430 - 1, 10 kHz – 250 MHz) was also used to detect PD pulse current which was used as a trigger of an oscilloscope (Tektronix: DPO7254, 2.5 GHz, 10 GS/s).

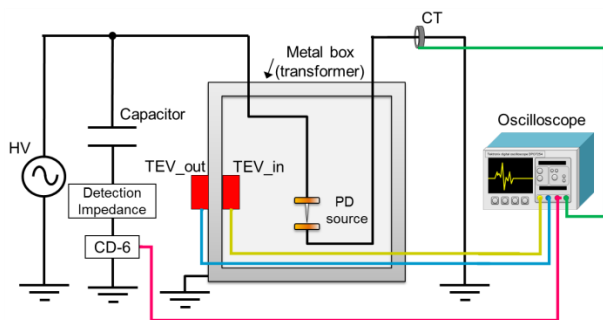

Figure 2: Experimental system to detect PD occurring in transformer model tank

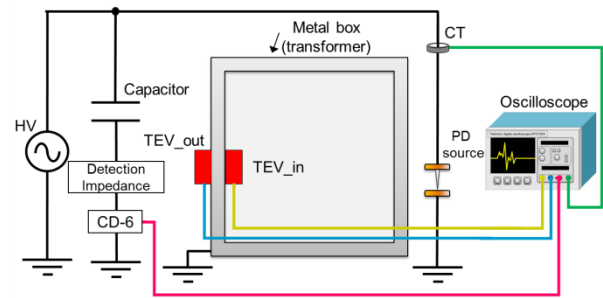

Figure 3: Experimental system to detect PD occurring outside of a transformer model tank

4 EXPERIMENTAL RESULTS

Figures 4 and 5 show example of waveform detected with the two TEV sensors TEV_in and TEV_out for the internal and external PD sources, respectively. Figures 6 and 7 show FFT of the results given in Figures 4 and 5 for internal and external PD with the charge 955 and 722 pC, respectively. It is obvious from Figure 4 that peak value of TEV_in and TEV_out is 170 and 43 mV, respectively. It should be noticed in Figure 5 that TEV_in hardly detects TEV signal for the external PD, while TEV_out for the internal PD detects TEV signal. It is also found in Figure 6 for the internal PD that FFT spectrum of both TEV_in and TEV_out signal intensity maxima appear at 300, 420, 590, 660 and 840 MHz. On the other hand, as shown in Figure 7 for the external PD, no such clear maxima in the FFT appears.

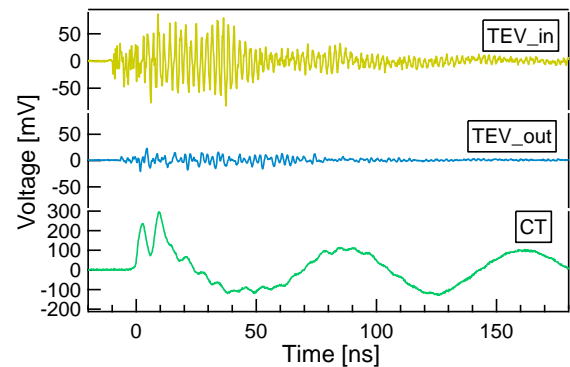

Figure 4: Detected waveform of internal PD

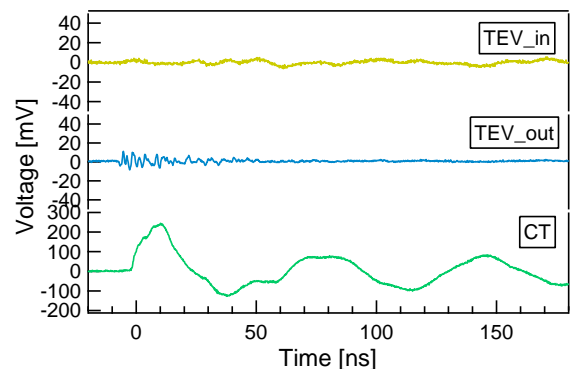

Figure 5: Detected waveform of external PD

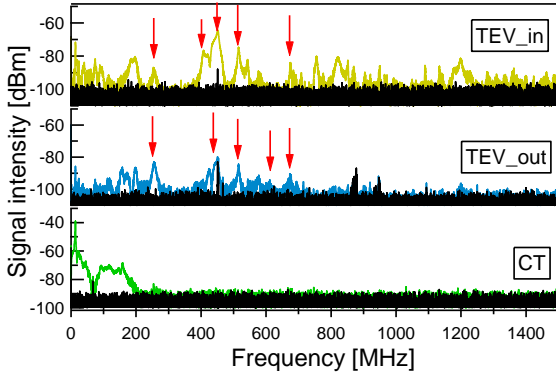

Figure 6: FFT analysis of detected waveform given in Fig.4 for internal PD

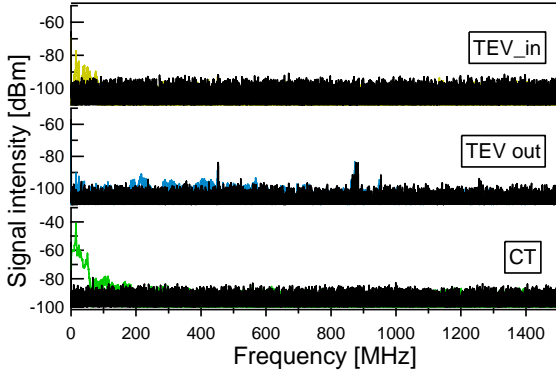

Figure 7: FFT analysis of detected waveform given in Fig.5 for external PD

5 DISCUSSION

As is shown in Figure 6, specific frequencies giving the maxima appear. These frequencies arise from resonant frequency determined by the size of the rectangular-shape tank playing as a rectangular cavity resonator. When electromagnetic waves are fed to a closed hollow box made of perfect conductor, the electromagnetic energy is stored in the box. Then, the resonance of electromagnetic waves occurs at specific frequencies. Resonant frequency f_c of the rectangular cavity resonator is given by:

$$f_c = \frac{c_0}{2\pi\sqrt{\epsilon_r}} \sqrt{\left(\frac{m}{W}\right)^2 + \left(\frac{n}{H}\right)^2 + \left(\frac{p}{D}\right)^2} \quad (1)$$

where, W , H and D is width, height and depth of the cavity resonator, respectively, and m , n and p are natural number. c_0 is the speed of light in vacuum, ϵ_r is the relative permittivity. Table 1 lists thus calculated resonant frequency for the model transformer tank. Note that calculated f_c and experimentally obtained one reasonably agree. Electromagnetic analysis software (MAGNA / TDM) was used for the model transformer tank. A Gaussian pulse with the center frequency 1.2 GHz was used as an excitation source. Mesh size of 10 mm \times 10 mm was adopted in the FDTD computation to meet Courant conditions. A bushing tank was simulated as porcelain insulator

with inside and outside diameter 8 and 10 mm, respectively, ϵ_r 5.9 on the top of the model transformer tank. Figure 8 shows distribution of calculated surface current density when electromagnetic waves have leaked from the bushing to excite the surface current flowing through the outer wall of the tank. Figure 9 shows waveforms of the inner and outer surface current in analysis. As can be seen in Figure 9, the surface current excited in the outer wall is the order of 1×10^{-6} times as much as that for the inner surface current. In other words, the surface current can be excited to the outer tank wall although it is very small. Luo et al also have conducted a similar experiment as the present one. Since the propagation loss in the outer wall is ignored, there is almost no difference in the waveform of TEV signal detected by TEV sensors attached onto the inside and outside of a tank near a dielectric discontinuity [1]. Conversely in our experiment, the two TEV sensors were attached inside and outside of the model tank away from the dielectric discontinuity (bushing), giving rise to difference in the detection sensitivity and arriving time for TEV signals detected with inner and outer sensors. Namely, experimentally obtained arriving time difference 3.40 ns for the two TEV sensors almost agree with 3.12 ns derived from the simulation. The surface current caused by electromagnetic waves leaking from the bushing contributes to generation of TEV signal. As a result, the obtained knowledge suggests usefulness of TEV detection method in detecting and monitoring PD.

Table 1: Resonance frequency of the transformer model

	[MHz]		
	$m = 0$	$m = 1$	$m = 2$
$m = 0$		300	600
$m = 1$	300	424.3	670.8
$m = 2$	600	670.3	848.5

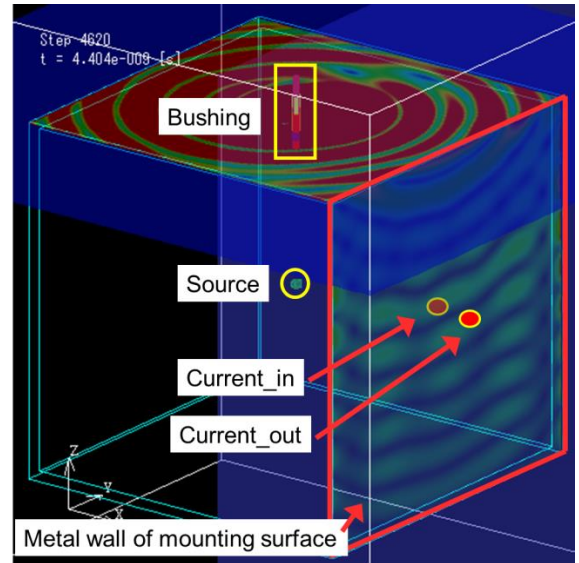

Figure 8: Analysis of surface current density in simulated transformer surface

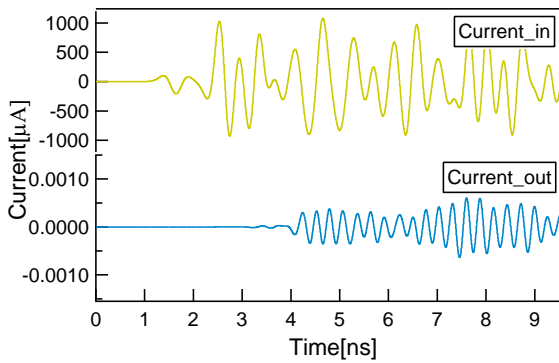

Figure 9: Calculated surface current waveform of analysis model

6 CONCLUSIONS

This paper deals with a detailed study on PD generated in transformers using TEV method. Experiment and analysis are carried out using an iron box model which simulates a tank of an actual transformer. The conclusions are summarized as follows: specific frequencies giving the maxima appear which arises from resonant frequency determined the size of the rectangular-shape tank. The resonance of electromagnetic waves occurs at specific frequencies and could detect as TEV signal. Experimentally obtained arriving time difference for the two TEV sensors installed on the inside and outside of the transformer model tank wall was found to be caused by the propagation path of TEV signal. It was confirmed that the surface current caused by electromagnetic waves leaking from the bushing contributes to generation of TEV signal.

REFERENCES

- [1] Luo Guomin. Transient Earth Voltage (TEV) based partial discharge detection and analysis, March 2013. Available from <http://repository.ntu.edu.sg/handle/10356/54865>, last accessed April 24, 2015.
- [2] Y. Li, Y. Wang, G. Lu, J. Wang, and J. Xiong, "Simulation of transient earth voltages aroused by partial discharge in switchgears," in International Conference on High Voltage Engineering and Application (ICHVE), pp. 309-312, 2010
- [3] Lihuo Wang, Haijing Wang, Lijun Wang, Hong Lu, Wenjun Ning, Shenli Jia, Ji Wu: "Experimental investigation of Transient Earth Voltage and Acoustic Emission Measurements of Partial Discharge Signals in Medium-voltage Switchgears", International Conference on Electric Power Equipment (ICEPE),1-a-Q-3, 2013