

Calorimetric Power-Loss Measurement of a High-Power Film Capacitor with Actual Ripple Current Generated by a PWM Inverter

Kazunori Hasegawa and Ichiro Omura
 Department of Biological Functions Engineering
 Kyushu Institute of Technology
 Kitakyushu, Fukuoka, Japan
 hasegawa[at mark] life.kyutech.ac.jp

Abstract—This paper proposes a calorimetric power-loss measurement method suitable for a high-power film capacitor used in the dc link of a high-power three-phase PWM inverter. The measurement method is characterized by using a thermally-insulated container and an evaluation circuit for dc-link capacitors. Introduction of the thermally-insulated container achieves an accurate power loss measurement that is of the order of 1 W. The evaluation circuit provides the equivalent ripple current waveform and dc-bias voltage to those of the high-power three-phase PWM inverter although its power rating is 1/24 of the high-power inverter. This combination makes it possible to measure the power loss of the capacitor under actual voltage/current condition at low cost. Experimental results obtained from a 1200-V 210-kVA system verify the viability and effectiveness of the proposed method.

Keywords—DC-link capacitors, power loss, calorimetric measurement, three-phase PWM inverters.

I. INTRODUCTION

DC-link capacitors in power electronic converters are a major constraint on the improvement of power density as well as of reliability [1, 2]. They tend to include a design margin of size or capacitance due to power loss. The minimum design margin of the capacitors is desirable, so that power loss estimation of the converters including the capacitors plays a crucial role in the next-generation power converters [3-9].

However, characteristics of the capacitors are usually evaluated by a single sinusoidal current such as 120 Hz, 1 kHz, and so on [10-12]. There are some kinds of “ripple current tester” instruments that provide a sinusoidal ripple current as well as a dc-bias voltage into the capacitor [10]. Actual current flowing out of the converter into the capacitor contains multiple frequency components, so that the power loss of the capacitor cannot be exactly estimated by a sinusoidal waveform. For example, the authors of this paper have revealed that the power loss of an aluminum electrolytic capacitor with the square-wave current injection cannot be estimated only by the root-mean-square (RMS) value of the capacitor current [7]. In addition, such a complex current makes it difficult to estimate the power loss by electric measurement.

Calorimetric measurements of power converters and components are attractive because they do not depend on voltage and current waveforms [3-7]. Fig. 1 shows three types of calorimetric measurement: (a) open type, (b) single-cased closed type, and (c) double-cased closed type [4, 5]. In the open type measurement, a device under test (DUT) is placed in a container, through which a coolant that is usually air flows. The temperature difference $T_{\text{out}} - T_{\text{in}}$ is in proportion to the

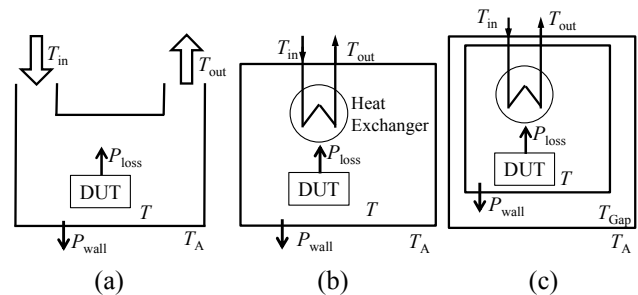

Fig. 1 Existing calorimetric measurement. (a) open type. (b) single-cased closed type. (c) double-cased closed type.

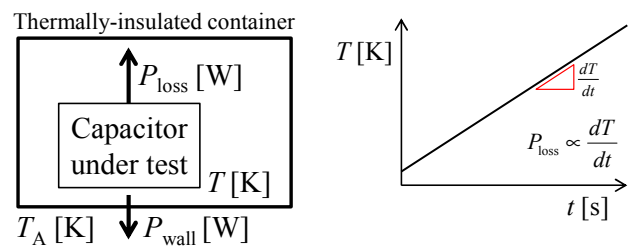

Fig. 2 Proposed calorimetric measurement for capacitors.

power loss P_{loss} if the leakage heat P_{wall} is negligible. Major difficulties in the open type are measuring the temperature and volume flow of air. The single-cased closed type employs a heat exchanger to compensate the power loss generated by the DUT. The coolant of the heat exchanger can be water, unlike the open type. Since measuring the temperature and volume flow of water is much easier than that of air, the single-case close type is more accurate than the open type. The double-cased closed type utilizes two containers, which allows minimizing the P_{wall} by means of adjusting the temperature in the gap, T_{Gap} to the temperature of the inner container, T . Thus, the double-cased closed type has a higher accuracy than the single-case one. In general, however, these closed types bring a long measuring time [4].

This paper proposes a calorimetric power-loss measurement method suitable for a high-power film capacitor used in the dc-link of a high-power three-phase PWM inverter. The measurement method employs a thermally-insulated container without a heat exchanger, which allows an accurate measurement that is of the order of 1 W and a short measuring time. Introduction of an evaluation circuit enables the capacitor to be tested by the actual ripple current waveform and dc-bias voltage of the high-power inverter, although the power rating of the evaluation circuit is 1/24 of the full-scale inverter.

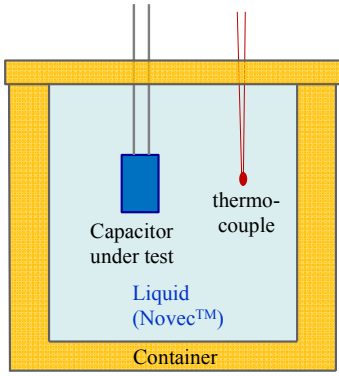

Fig. 3 Implementation of the calorimetric measurement

II. CALORIMETRIC POWER-LOSS MEASUREMENT

A. Principle of measurement

Fig. 2 shows basic principle of the proposed calorimetric measurement using a thermally-insulated container, in which P_{loss} is the power loss of the capacitor under test and P_{wall} is a leakage heat through the container. The heat quantity stored in the container, Q [J] is given by

$$Q = \int (P_{\text{loss}} - P_{\text{wall}}) dt \approx \int P_{\text{loss}} dt \quad (1)$$

where P_{wall} is negligible if the container has a sufficient thermal resistance. The heat quantity Q is also expressed as the product of the temperature T [K] and the total heat capacity of the container, H_C [J/K] as follows:

$$Q = H_C (T - T_0) \quad (2)$$

where T_0 stands for the initial value of the temperature. Substituting Eq. (1) into Eq. (2) and differentiating it with respect to time result in

$$P_{\text{loss}} = H_C \frac{dT}{dt} \quad (3)$$

Thus, one can obtain the power loss from the slope of the temperature, dT/dt .

B. Implementation of measurement

Fig. 3 illustrates the implementation of the calorimetric measurement, which consists of the thermally-insulated container filled with a liquid that stores the heat (power loss) generated by the capacitor. A capacitor under test and a thermocouple are immersed in the liquid. Requirements of the liquid are as follows:

- Galvanic insulation
- Low viscosity to make temperature distribution uniform
- Chemically stable and no influence on the capacitor under test

This paper selects Novectm 7300 as the liquid, which is a fluorine liquid utilized in many industrial applications such as heat transfer, electronic testing, and cleaning [15]. It has a greatly high resistivity of $3 \times 10^9 \Omega\text{m}$ and a viscosity as low as water. Note that a silicone oil could be a candidate of the liquid, but has a much higher viscosity than the Novectm. Such a high viscosity brings uneven temperature distribution that degrades the accuracy of the temperature measurement.

C. Verification with a Resistor

Fig. 4 illustrates the setup used for verification of the accuracy of the proposed method, in which a resistor is

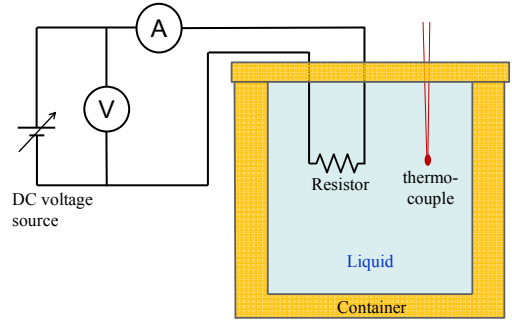
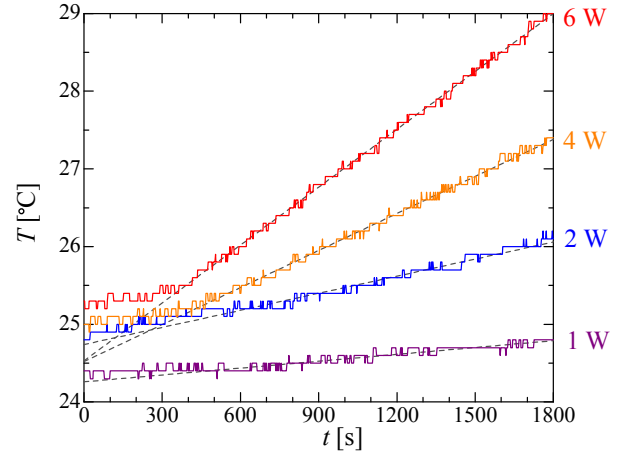
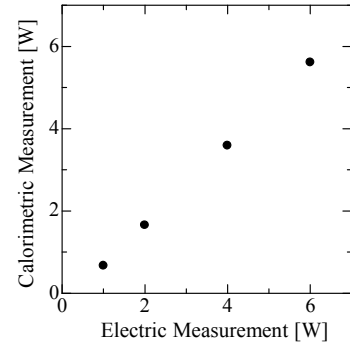

Fig. 4 Verification of accuracy with a resistor



(a)



(b)

Fig. 5 Results of the calorimetric measurement with the resistor. (a) Temperature measurement. (b) Relation between electric measurement and calorimetric measurement.

immersed in the liquid and is connected to a dc voltage source. The dissipated power of the resistor is measured by the applied voltage and current (electric measurement) as well as the proposed calorimetric measurement method.

Fig. 5(a) shows experimental results of the calorimetric measurement, where the Novectm had a volume of 1200 cm^3 and a heat capacity of 2.26 kJ/kgK . The heat capacity of the resistor is neglected because its physical volume is much smaller than the volume of the Novectm. The dissipated power by the electric measurement was adjusted to be 1 W, 2 W, 4 W, and 6 W. Fig. 5(b) shows relation between the dissipated power of the electric measurement and that of the calorimetric one, which indicates that the calorimetric measurement had a good linearity and a small error less than

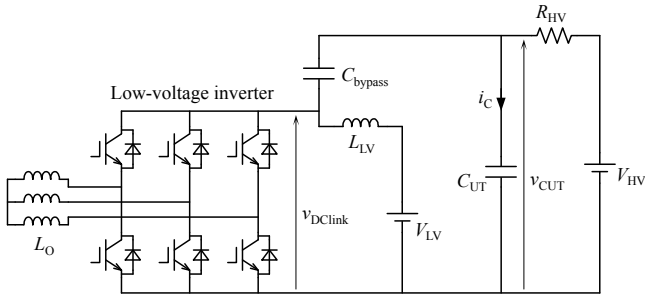

Fig. 6 Evaluation circuit used for providing ripple current and dc-bias voltage.

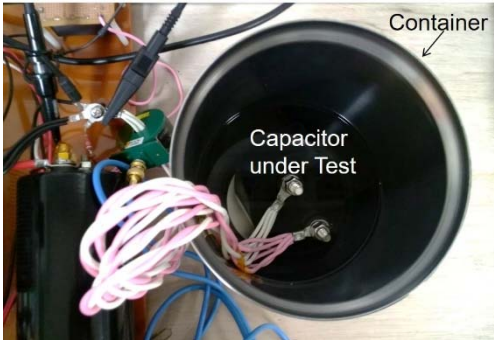

Fig. 7 Exterior of the container

1 W. The reason why the result of the calorimetric measurement was always somewhat lower than that of the electrical measurement is that the actual heat capacity included that of the container.

III. EVALUATION CIRCUIT PROVIDING ACTUAL RIPPLE CURRENT AND DC-BIAS VOLTAGE

A. Circuit Configuration

The authors of this paper have proposed an evaluation circuit for a dc-link capacitor [13], which provides the same ripple current and dc-bias voltage as the full-scale high-power inverter, although its power rating is much smaller than the full-scale inverter.

Fig. 6 shows the evaluation circuit that employs a small-power-rating low-voltage three-phase inverter [13]. The low-voltage inverter is just used for injecting the ripple current, while the high-voltage dc supply provides a dc-bias voltage. The current rating of the low-voltage inverter is full-scale, whereas voltage rating is downscale. Hence, the circuit operates as a full-scale voltage-rating and full-scale current-rating inverter from the standpoint of the dc bias voltage and ripple current. This concept is similar to the circuits proposed in [11] and [12] in terms of the combination of a ripple current source and a dc voltage supply, whereas it presents the same current waveform as that generated by the inverter. The bypassing capacitor C_{bypass} is used for circulating the ripple current. The choke inductor L_{LV} and the resistor R_{HV} block the ripple current, where their impedances should be much larger than those of capacitors C_{UT} and C_{bypass} [13]. Note that the inductor and the two capacitors do not result in oscillation in practice [14].

Table I Ratings and circuit parameters for experiment

Rated power of the system	P	210 kVA
Rated power of the inverter	P_{inv}	9 kVA
AC current rating	I_O	170 A
AC voltage rating	V_O	31 V
Low-voltage dc source	V_{LV}	50 V
High-voltage dc source	V_{HV}	1.2 kV
Load inductor	L_O	330 μ H
Carrier frequency	f_c	10 kHz
Output frequency	f_o	50 Hz
High-voltage choke resistor	R_{HV}	1 k Ω
Low-voltage choke inductor	L_{LV}	4 mH
Capacitor under test	C_{UT}	100 μ F
Unit capacitance constant of the capacitor under test [16]	H	0.34 ms
Bypassing capacitor	C_{bypass}	100 μ F
Rated current of the capacitors	$I_{C_{rms}}$	64 A

B. Experimental Setup for Calorimetric Measurement

Table I summarizes ratings and circuit parameters of the evaluation circuit, where the circuit acts as a 210-kVA high-power inverter although the rated power of the inverter is 9 kVA that is 1/24 of that of the high-power inverter.

Fig. 7 is a photo of an exterior of the experimental setup, where the container was filled with the Novec. Note that the container was actually covered with a rubber plate when the setup runs. The heat capacity of the Novec was 2.26 kJ/kgK, while that of the capacitor under test was 0.6 kJ/kgK. Thus, the total heat capacity in the container H_C was 2.86 kJ/kgK.

IV. EXPERIMENT

A. Experimental Waveforms of the Evaluation Circuit

Fig. 8 shows experimental waveforms of the evaluation circuit when it operated at the rated power. The authors confirmed that the ripple current $i_{C_{UT}}$ as shown in Fig 9(a) was almost the same as that of the high-power inverter with computer simulation. The root-mean-square (RMS) value of the ripple current was 64 A that is the same as the rated current of the capacitor under test. The capacitor voltage as shown in Fig. 9(b) stayed at 1200 V that is the same as the high-voltage dc source V_{HV} . Thus, the evaluation circuit provided the same current/voltage stress to the capacitor under test as the 210-kVA high-power inverter. The dc-link voltage shown in Fig. 9(c) had a dc mean of 50 V that is 1/24 of the capacitor voltage and contained the ripple voltage of the capacitor.

B. Calorimetric Power-Loss Measurements

Fig. 9 shows the temperature of the liquid in the container with the evaluation circuit running, where the RMS values of the ripple current were adjusted to be 64 A (100% of the rated current of the capacitor), 45 A (70%), and 31 A (49%). The temperature was almost a linear function of time due to a constant power loss. The fitting lines present that the power losses with the RMS values of 64 A, 45 A, and 31 A were 32 W, 17 W, and 8 W, respectively. These results indicate that the power loss of the capacitor is almost in proportion to the square of the RMS value. Although these experiments were carried out over 1200 seconds (20 minutes), the slopes of the temperatures had already been constant after 300 seconds

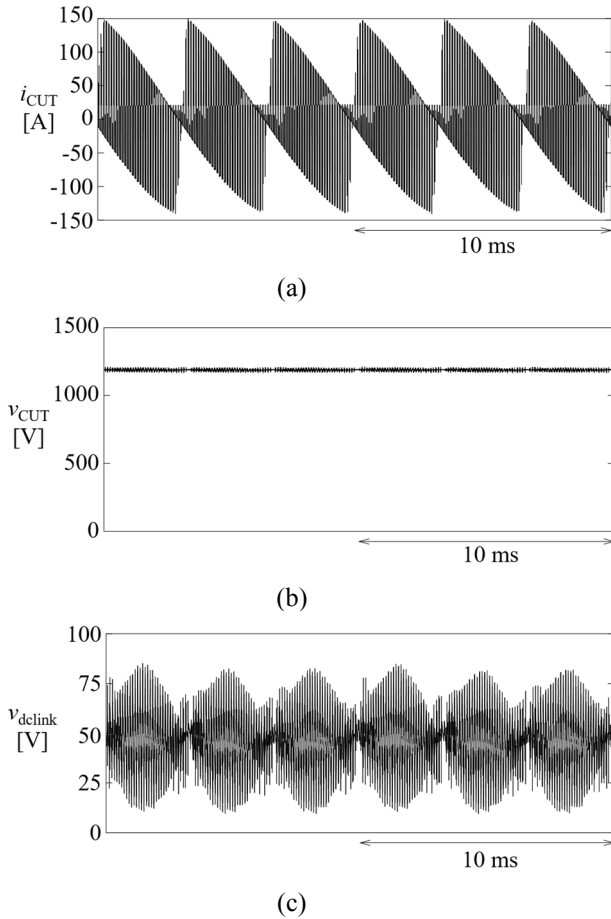

Fig. 8 Experimental waveforms of the evaluation circuit

passed. Hence, the measuring time of the proposed method is around 5 minutes in practice.

V. CONCLUSION

This paper has proposed a calorimetric power-loss measurement method suitable for a high-power film capacitor used in the dc link of a high-power three-phase inverter. Introduction of a thermally-insulated container into the calorimetric measurement achieves power-loss measurement that is of the order of 1 W with a measuring time of 5 minutes. The evaluation circuit enables the capacitor to be tested by the actual ripple current waveform and dc-bias voltage, although the power rating of the circuit is 1/24 of the high-power inverter. A 1200-V 210-kVA experimental system is developed, constructed, and tested to confirm the viability and effectiveness of the proposed method.

REFERENCES

- [1] J. W. Kolar, U. Drofenik, J. Biela, M. Heldwein, H. Ertl, T. Friedli, and S. Round, "PWM converter power density barriers," *IEE Japan Trans. Ind. Appl.*, vol. 128, no. 4, pp. 468-480, 2008.
- [2] H. Wang and F. Blaabjerg, "Reliability of capacitors for dc-link applications in power electronic converters—an overview," *IEEE Trans. Ind. Appl.* vol. 50, no. 5, pp. 3569-3578, 2014.
- [3] G. Chen, C. Xiao, and W.G. Odendaal, "An apparatus for loss measurement of integrated power electronics modules: design and analysis," *IEEE Ind. Appl. Soc. Annu. Meeting*, pp. 222-226, 2002.

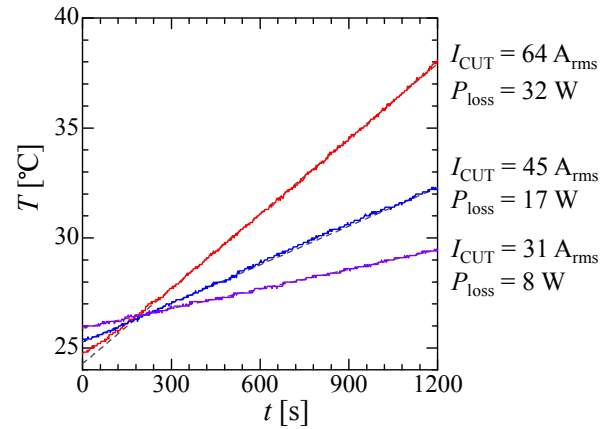

Fig. 9 Experimental results of the calorimetric power-loss measurement with different RMS values of the ripple current.

- [4] C. Xiao, G. Chen, E.G.H. Odendaal, "Overview of Power Loss Measurement Techniques in Power Electronics Systems," *IEEE Trans. Ind. Appl.*, vol. 43, no. 3, pp. 657-664, May/Jun., 2007.
- [5] D. Christen, U. Badstuebner, J. Biela, and J.W. Kolar, "Calorimetric power loss measurement for highly efficient converters," in *Conf. Rec. of International Power Electronics Conference (IPEC)*, pp. 1438-1445, 2010.
- [6] J. M. Miller, C. W. Ayers, L. E. Seiber, and D. B. Smith, "Calorimeter evaluation of inverter grade metallized film capacitor ESR," in *Proc. of IEEE ECCE*, pp. 2157-2163, 2012.
- [7] J. Itoh and A. Nigorikawa, "Experimental Analysis on Precise Calorimetric Power Loss Measurement Using Two Chambers," *EPE-PEMC*, 2012.
- [8] K. Hasegawa, K. Kozuma, K. Tsuzaki, I. Omura, and S. Nishizawa, "Temperature rise measurement for power-loss comparison of an aluminium electrolytic capacitor between sinusoidal and square-wave current injections," *Microelectron. Rel.*, vol. 64, pp. 98-100, 2016.
- [9] P.-Y. Huang, H. Nagasaki, and T. Shimizu, "Capacitor Characteristics Measurement Setup by Using B-H Analyzer in Power Converters," *IEEE Trans. Ind. Appl.*, vol. 54, no. 2, Mar./Apr. 2018.
- [10] *RIPPLE CURRENT TESTER MODEL 11800/11801/11810*, Chroma ATE Inc. 2014. [Online]. available: <http://www.chromaate.com/File/Download/42014>
- [11] A. M. R. Amaral, and A. J. M. Cardoso, "Estimating aluminum electrolytic capacitors condition using a low frequency transformer together with a dc power supply," in *Proc. of IEEE ISIE*, pp. 815-820, 2010.
- [12] M. Makdessi, A. Sari, P. Venet, P. Bevilacqua, and C. Joubert, "Accelerated Ageing of Metallized Film Capacitors Under High Ripple Currents Combined with a DC Voltage," *IEEE Trans. Power Electron.*, vol. 30, no. 5, pp. 2435-2444, May 2015.
- [13] K. Hasegawa, I. Omura, and S. Nishizawa, "Design and Analysis of a New Evaluation Circuit for Capacitors Used in a High-Power Three-Phase Inverter," *IEEE Trans. Ind. Electron.*, vol. 63, no. 5, pp. 2679-2687, May 2016.
- [14] K. Hasegawa, I. Omura, and S. Nishizawa, "A New Evaluation Circuit with a Low-Voltage Inverter Intended for Capacitors Used in a High-Power Three-Phase Inverter," *IEEE APEC*, pp. 3032-3037, Mar. 2016.
- [15] *3M™ Novec™ 7300 Engineered Fluid*, 3M Product Information, [Online]. available: <http://multimedia.3m.com/mws/media/3387130/3mtm-novectm-7300-engineered-fluid.pdf>
- [16] H. Fujita, S. Tominaga, and H. Akagi, "Analysis and design of a dc voltage-controlled static var compensator using quad-series voltage-source inverters," *IEEE Trans. Ind. Appl.*, vol. 32, no. 4, pp. 970-977, 1996.