

## Design Concept of Horyu-V - The Space Environment Explorer

Mohamed IBRAHIM <sup>\*,†</sup>, Batsuren AMGALANBAT, Muhammad ALKALI, Nori AIT-MOHAMMED,  
Ammarin PIMNOO, Pauline FAURE, Yuta OKUMURA, Shunsuke IWAI, and Mengu CHO

Kyushu Institute of Technology  
1-1 Sensui-cho, Tobata-ku, Kitakyushu-shi, Fukuoka, 804-8550, JAPAN  
[mohamed@es.ise.kyutech.ac.jp](mailto:mohamed@es.ise.kyutech.ac.jp)

### SUMMARY

Horyu-V, the Space Environment Explorer is a scientific satellite developed for the purpose of gathering detailed measurements about the space environment effects on satellite systems. Horyu-V project involves students of the Kyushu Institute of Technology. It allowed a multi-cultural environment and an excellent tool for education. The students are responsible for the design, assembly, integration, test of the satellite, and augmentation of the existing ground segment facility for the operation of the satellite. It will enhance capacity building for the students, and scientific research components for upcoming studies.

KEY WORDS: Horyu project, Space environment, Discharging mission, Charged particles

---

\* Corresponding author, HORYU-V Project Manager.

† E-mail: [mohamed@es.ise.kyutech.ac.jp](mailto:mohamed@es.ise.kyutech.ac.jp)

Received February 9, 2014, Revised February 28, 2014, Accepted March 10, 2014.

## 1. INTRODUCTION

The history of Horyu satellites, all developed by students at Kyushu Institute of Technology (Kitakyushu, Japan), began in 2006 with Horyu-I, a 10 cm cubic shaped satellite. Horyu-I main mission was to acquire sensors data and demonstrate the CMOS camera ability. Horyu-II project started in 2010 with four mission objectives dealing with the space environment study. Moreover, Horyu-II was a precious tool for the local educational program for elementary and junior high school students. In May 2012, Horyu-II was successfully launched as an H-IIA piggy-back payload from the Tanegashima Space Center (Japan). The first telemetry was successfully received a few hours later. From November 2012, three projects started in parallel: Horyu-III, Horyu-IV, and Horyu-V, all dedicated to research on the space environment.

Exploitation of the spatial domain begins first of all by understanding its environment which is very different to the Earth environment. The natural space environment affects the spacecraft design, development and operation, and is the cause of many mission failures. This environment is composed of various elements such as particles (protons and ions) radiations caused by solar energetic events which can cause radiation damage, disruption to logic circuits and astronauts problems, space debris and meteoroids can impact spacecraft at high velocities destroying mechanical or electrical parts, hot plasma surrounding the Earth can cause spacecraft charging especially in aurora zone (high energy electrons). The electrostatic discharges (ESDs) are one of the main anomaly causes for spacecraft failures and contain the largest number of forms followed by the single event upsets anomalies and radiation damage. Therefore, discharge phenomena in space need to be studied in detail to mitigate them for the upcoming space missions. The spacecraft charging study is the main mission of the Horyu satellites.

In addition to studying space environment, the HORYU-V satellite is demonstrating two novel technologies: 1) FPGA based Multi-Processor System-on-Chip design for high performance computing in space, and 2) Super capacitor power based subsystem. It carries five other payloads to facilitate studying and capturing of the spacecraft charging effects as well as detecting the micro space debris: 1) discharge current wave measurement on solar array and discharge image capture, 2) orbital demonstration of High Voltage Solar Array (HVSA) technology that does not arc at 300 V or higher, 3) orbital demonstration of Electron-emitting Film (ELF) for spacecraft charging mitigation, 4) simultaneous measurement of energetic electrons, energetic ions, low-energy plasma and internal/surface charging, and 5) detection of debris-impact-induced-short-circuits on the satellite electrical circuits.

The purpose of this paper is to describe the design concept of the Horyu-V satellite missions as well as providing an overview of the satellite master plan and estimated budget which might help satellite developers in planning and developing satellites in the 50kg.

In the following sections we present the orbit definition, the system bus architecture, HORYU-V payloads, AOCS and EPS specifications, Satellite Structure, communication and mission control and finally the conclusion.

## 2. ORBIT DEFINITION

The definition of Horyu-V orbit has been done according to the level of the electron energy in atmosphere around the Aurora zone. To satisfy this requirement, HORYU-V orbit was selected be at an altitude of 666 km and an inclination of 98.6 deg. Table 1 shows the main the orbital characteristics and parameters of Horyu-V.

**Table 1. Characteristics of Horyu-V Orbit**

<b>Altitude [km]</b>	666
<b>Inclination [deg]</b>	98.6
<b>Satellite Velocity [km/s]</b>	7.52
<b>Semi-major Axis [km]</b>	7,044

<b>Eccentricity</b>	0.0014
<b>Right Ascension of Ascending Node (RAAN) [deg]</b>	112
<b>Argument of Perigee [deg]</b>	72
<b>Mean Anomaly [deg]</b>	70
<b>Local Solar Time</b>	10:00 am (descending)
<b>Orbit Revolution Time [min]</b>	98.06
<b>Number of Orbits [rev/day]</b>	14.68
<b>Ground Track Repeat</b>	367 orbits in 25 days
<b>Maximum Visibility Time [min]</b>	13.7
<b>Maximum Eclipse duration [min]</b>	35.35
<b>Orbit Life Time [year]</b>	2

STK satellite tracking system software was used in our study. The satellite tracking system software allowed us to determine Horyu-V two-line elements data. It was used to analyze and simulate the Horyu-V orbit including ground track, footprint area, and epoch. Figure 2 shows Horyu-V ground track as simulated by STK within a day consisting of 14.68 orbits. Figure 3 shows the 10:00AM of Local Solar Time (LST) above KIT Control Ground Station (KIT-CGS).

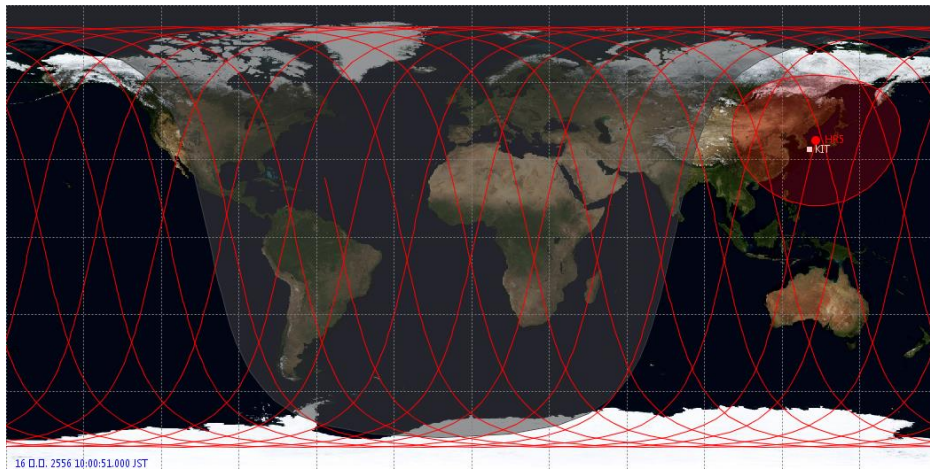

**Fig. 1. Ground Track Simulation**

HORYU-V dimensions are 50×50×50 cm and mass is about 50 kg. The satellite shall de-orbit within 25 years after its launch. De-orbit time is relative to the satellite's area and mass. Figure 2 shows that HORYU-V will decay within 18 years as calculated by the DEbris MItigation Standard support Tool (DEMIST) version 0.6. The parameters used for the calculation are given in Table 2.

**Table 2. Parameters used in de-orbit calculations**

<b>Altitude [km] (without Earth radius)</b>	666
<b>Altitude [km] (with Earth radius)</b>	7,044
<b>Area [m<sup>2</sup>]</b>	3.5
<b>Mass [kg]</b>	50
<b>Area-to-Mass Ratio [m<sup>2</sup>/kg]</b>	0.0175a

<sup>a</sup>A factor of 0.25 has been used in the calculation to take into account the cross-section

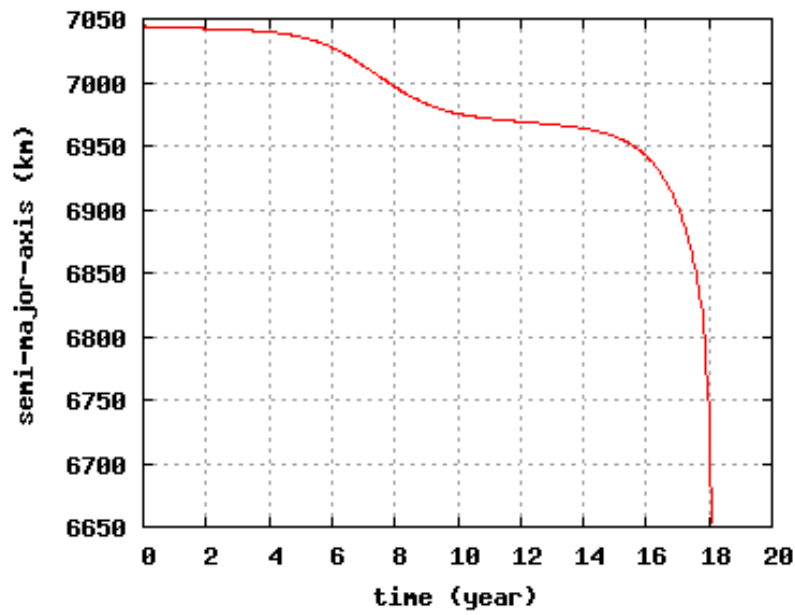

**Fig. 2. HORYU-V Orbital Decay. The semi-major axis included the average Earth radius (6,378 km).**

The Space ENVIRONMENT Information System (SPENVIS) online software package was used to simulate the space environment electrons density at the HORYU-V orbit. Figure 3 shows electron density at different altitudes. The altitude and inclination of the selected orbit guarantees: 1) sufficient mission lifetime without fast drag into atmosphere, 2) suitable for Japanese as well as other launchers, and 3) electron density that is suitable to cause spacecraft surface charging.

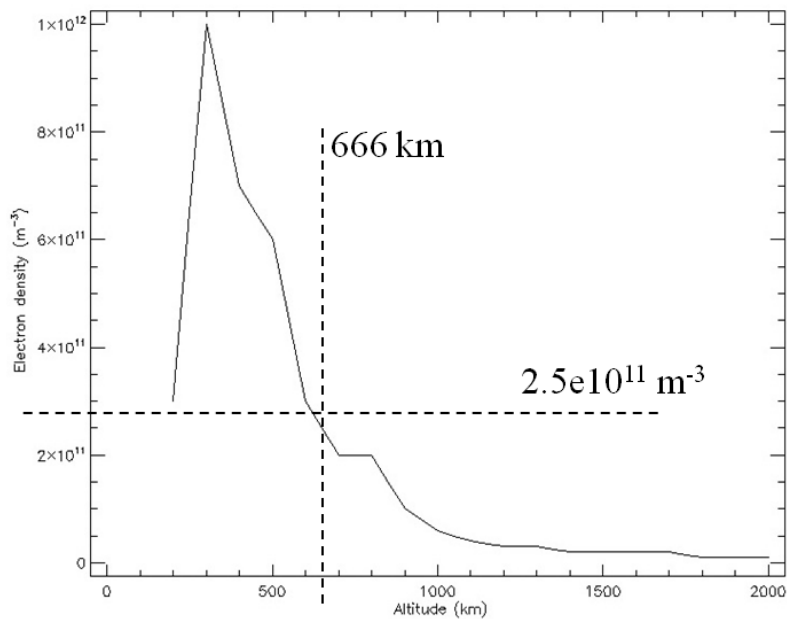

**Fig. 3. Electron Density at Different Orbit Altitudes.**

### 3. HORYU\_V SYSTEM BUS ARCHITECTURE

The Horyu-V satellite system uses the RS422 interface to communicate between the On Board Computer (OBC) and the rest of the subsystems and missions. The main mission of measuring the discharge events waveform and capturing of the discharge video is operating autonomously. The OBC will retrieve the information from the discharge mission storage memory during the communication session. The RS422 interface is used to carry interface commands to the subsystems and retrieve missions/telemetry data. Fig. 4 presents the overall system bus architecture.

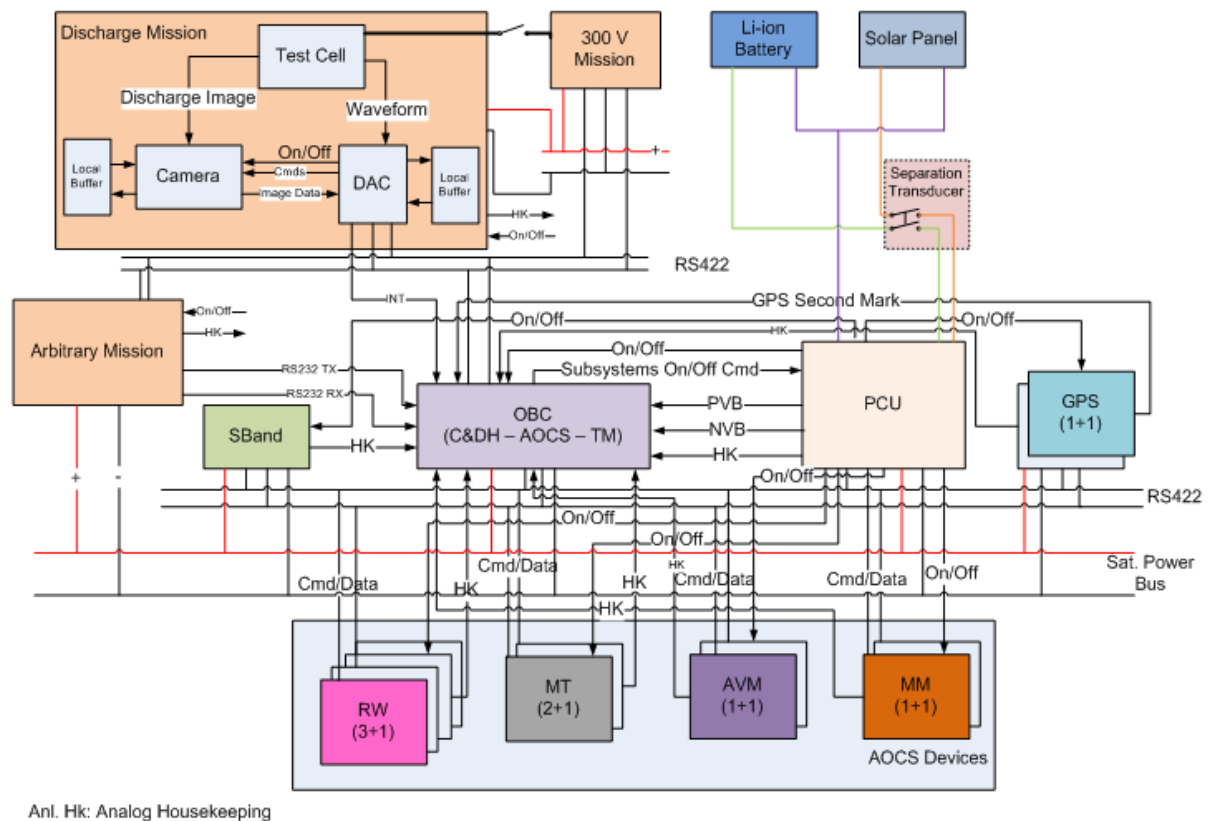

**Fig. 4. System Bus Architecture**

The Horyu-V on-board computer will be a commercially available system that has flight heritage and uses space approved components to guarantee high level of system reliability. Table 1 presents the overall system estimated specifications. The OBC will carry on the tasks of Command and Data Handling (C&DH), Telemetry (TM) storage and the Attitude Orientation and Control Software (AOCS). The AOCS will control 3 Magneto-Torques (MT), 2 as main and 1 as backup, and 4 Reaction Wheels (RW), 3 as main and 1 as backup. It will read 2 Magneto-Meters (MM), 1 as main and 1 as backup, and 2 Angular Velocity Measures (AVM), 1 as main and 1 as backup. A Global Positioning System (GPS) receiver will provide accurate timing to the OBC and AOCS as well as (seconds tick marks) to synchronize the timing of the OBC with the GPS. The Power Conditioning Unit (PCU) is responsible to power the satellite subsystems, it switches on/off the subsystems based on commands from the OBC. After separation from the launcher the PCU will receive the signal from the separation transducer which will enable the PCU to connect the main satellite power bus to the battery. The PCU will send a Negative Voltage Balance (NVB) signal to the OBC when the battery voltage is lower than certain threshold limit. When the NVB signal is received, the OBC will keep the minimum subsystems running, mainly the PCU, AOCS. It will not activate any mission until the battery is charged again. To indicate that the battery is recharged the PCU will generate the Positive Voltage Balance (PVB) signal to the OBC. All House Keeping

(HK) telemetry data such as temperature, switch on/off status, transmitter power measurement, main bus voltage, battery voltage, over load current values, and on board total current will be sent to the OBC for storage. The OBC software will be interrupted if an essential HK data has critical values. For example, if there is an overload detected by the current sensors then the OBC software will be interrupted to shutdown the subsystem with the overload and take necessary recovery actions. An arbitrary mission which can communicate on the RS232 interface can be added to the satellite later as long as the mass and power budgets are within the permissible limits. The discharge mission will have its own control system to detect the event of discharge. A current sensor will detect the discharge event when the current exceeds certain threshold. It will trigger the discharge mission to start the camera to capture the discharge event. The captured video will be stored in the local buffer of the capturing system. Also the discharge wave current data will be stored in the local buffer after conversion into binary form through the Analog to Digital (ADC). The ADC reads the discharge current from a solar panel test cell. The test cell will be connected to the 300v generating mission to help creating a potential difference between the test cell base and surface. The surface of the test cell will collect electrons from surface charging due to the plasma environment while the base will be arbitrarily connected to the 300v to facilitate the occurrence of the discharging event.

**Table 1. On-board computer preliminary specifications**

<b>Weight [kg]</b>	< 5Kg
<b>Power [Watt]</b>	< 10W
<b>Size</b>	< 6U
<b>Interface</b>	RS422, RS232, Spacewire, SPI
<b>Application Memory [Mbytes]</b>	32
<b>Throughput[MIPS]</b>	100
<b>Storage Memory[ Mbytes]</b>	32
<b>Radiation [Krad (Si)]</b>	>5
<b>Vibration</b>	Sinsuidal: >20g, Random: >10Grms, all axis
<b>Temperature</b>	-20C° to +50C°

Figure 5 presents the Telemetry, Tracking and Command (TT&C) system block diagram. The system is responsible for decoding the received commands and data arrays from the ground station according to the used packet telecommand protocol. It will send the decoded commands to the OBC to carry out the C&DH function. It will encode the TM data received from the OBC and send it to the ground station during the communication session based on the used TM encoding protocol. It will receive direct TM data from the S-Band and UHF/VHF communication systems. This TM data does not need to be stored at the OBC as the communication systems are active only during the communication session. Mission data which will be downloaded through the S-Band communication link will also be encoded in the TT&C after reception from the C&DH. In figure 5, the interface with the C&DH Software ( C&DHS) is done through the OBC RS422 link. Authentication of the received command based on security key will implemented in the TT&C. In case of emergency cases such as loosing communication for long time or failure of the OBC, the TT&C will issue commands to control the satellite and trying to recover it. The HORYU-V has two communication systems: 1) S-Band communication system for downloading of the mission data, and 2) UHF/VHF communication link for uploading of commands.

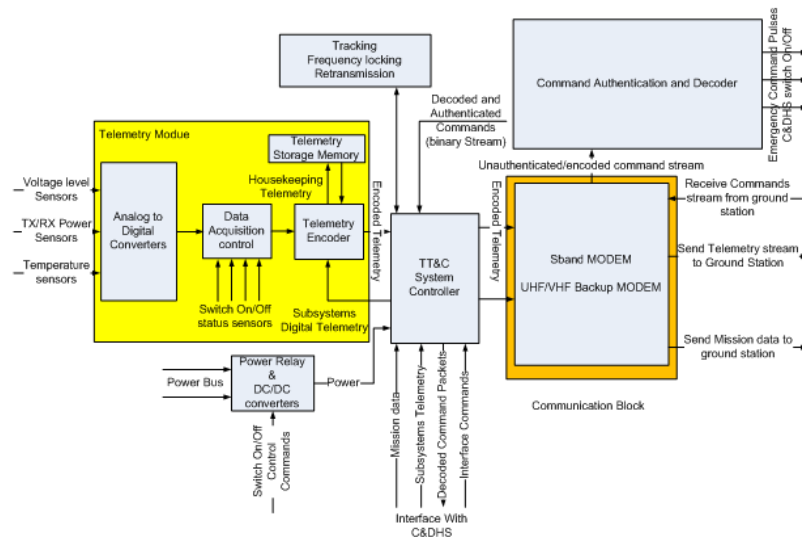

Fig. 5. Telemetry, Tracking and Command (TT&C) System Block Diagram.

## 4. HORYU-V PAYLOADS

### 4.1. Discharge Mission

The discharge mission aims at measuring the waveform resulting from a discharge on a test cell solar array and at capturing the image of the discharge. The discharge process has only been studied through on-ground experiments and even if the discharge process is understood to a certain extent, there is no certainty that what has been observed on-ground is the same as what is happening in space. The mission will be executed for the first time in the world and the outcome will be critical to better understand the discharge mechanism and thus, offer better protection to the spacecraft against discharges. Discharge mission can be divided in four main parts:

- 1) the solar array samples, which only purpose will be to withstand discharges;
- 2) generation of 300 V to force the discharge to occur on the solar array samples;
- 3) data acquisition card to measure the blow-off current vs. time (figure 6.a);
- 4) camera to take pictures of the discharge events (figure 6.b).

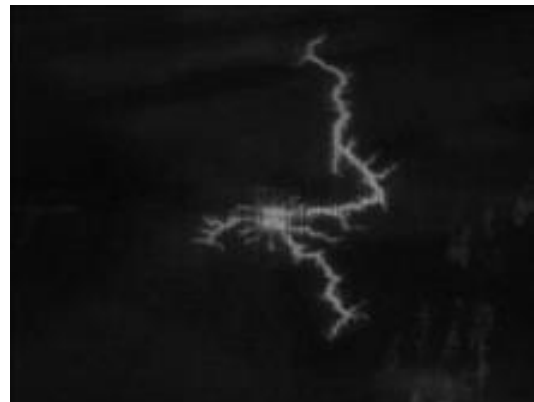
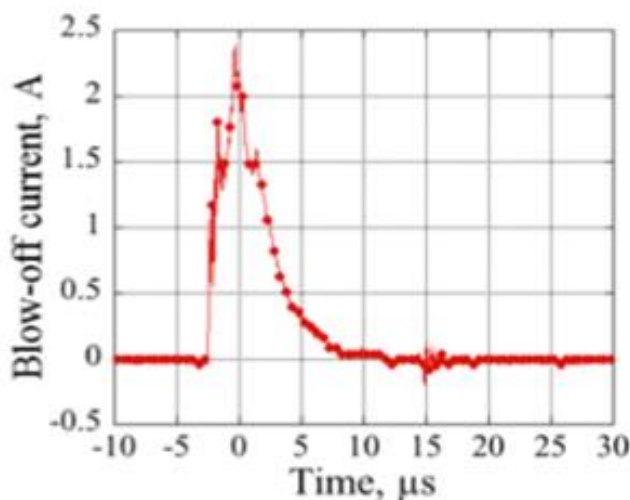

Fig. 6. Discharge mission. a) Discharge waveform. b) Discharge image as obtained during on-ground experiment [2].

## 4.2. Charging Mission

In low Earth orbit, the plasma environment is the most critical factor to take into account when designing a spacecraft. Depending on the energy of the plasma particles, charging effects can be observed either externally, on the spacecraft surface, or internally, on components mounted inside the spacecraft. The charging mission aims at simultaneous measurement of the electrons energy, the ions energy, for both surface and internal charging, and these at different locations on the orbit. The mission will be a world premiere and the results obtained will be helpful to spacecraft designers. Charging mission can be divided into two main parts: 1) external charging measurement - high energy electrons (10 eV~20 keV) and high energy ions (2 keV~20 keV) measurement, and a Langmuir probe (<10 eV), and 2) internal charging measurement - high energy electrons (500 keV~5 MeV).

The instruments for the external charging measurements will be provided by the National Cheng Kung University, Taiwan. The high energy electrons instrument is referred as the aurora electron spectrometer (AES), and the high energy ions instrument is referred as the supra thermal electrons, ions, neutrals (STEIN) [3]. The instruments for the internal charging measurements will be provided by the Surrey Space Centre, and is referred as SURF [4], the surface charging monitor devices are referred as SCM. The charging mission schematic is shown in figure 7.

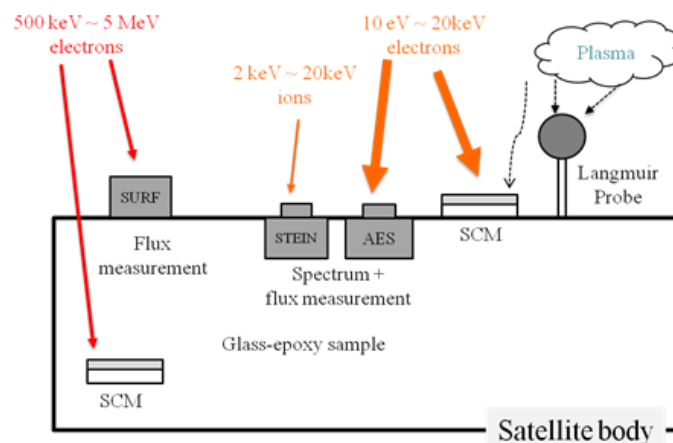

Fig. 7. Schematic of the Instruments for the Charging Mission.

## 4.3. High Voltage Solar Array Mission

Spacecraft are exposed to arcing when generated more than 200 V in orbit. Horyu-V will perform several arcing test, and to fulfill that purpose, the high voltage solar array mission will create an environment prone to Electro Static Discharging (ESD) by generating several hundred volts voltages [5]. The generated voltage could be able to test and evaluate ESDs when different high voltages are applied. To accommodate the voltage changes, the mission is divided into five modes:

- 1) **Mode 0** - to make sure that the discharge detection circuit is operating correctly;
- 2) **Mode 1** - initial generation operation to confirm the soundness of the 300 V system, 25sec will be dedicated to measure the temperature and potential;
- 3) **Mode 2** - 300 V generation mode. Temperature, potential, power generation potential, and discharge detection will be measured;
- 4) **Mode 3** - 400 V generation mode. The same parameters as in Mode 3 will be measured;
- 5) **Mode 4** - 500 V generation mode. The same parameters as in Mode 3 will be measured.

## 4.4. Debris Sensor Mission

Space debris are another critical parameter to take into account in space environment. Debris smaller than 1 cm cannot be continuously detected by ground-based observations. Moreover, space debris environment models present great discrepancies in their results. The debris sensor mission is thus aiming at collecting in-situ data on



small space debris, i.e., with a diameter ranging from 100  $\mu\text{m}$  to 1 mm to improve our knowledge on the small space debris population and to better assess the risk that small debris represent. The collected data will include the number of impacting debris and an estimation of the impacting debris size (Fig. 8). Another aim of the mission will be to estimate whether debris can be held responsible of sudden energy loss when impacting on solar panels (Fig. 9). The debris sensor has been developed by the Institute for Q-shu Pioneer of Space in cooperation with the Japan Aerospace Exploration Agency (JAXA).

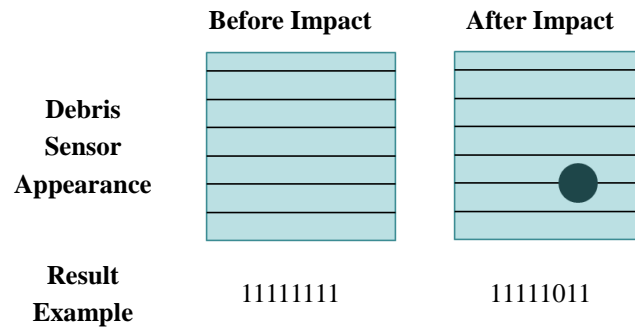

**Fig. 8. Result Example after the Impact of Space Debris on the Debris Sensor.**

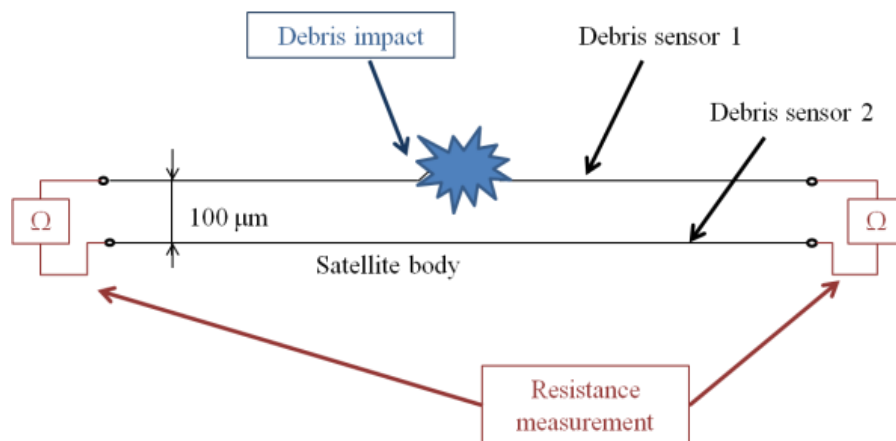

**Fig. 9. Evaluation of the Influence of Debris Impacts on the Sudden Power Loss of Solar Panels**

#### 4.5. Electron-Emitting Film mission

The high voltage solar array mission will generate voltages of 300 V and higher, but with such high voltages, it is very likely that discharges will occur, possibly damaging solar cells and/or other components nearby. To counteract this negative effect, an electron-emitting film has been developed at Kyushu Institute of Technology to mitigate charging and thus successfully generate high voltages without favoring ESDs [6][7].

#### 4.6. Power, mass and size budget for each mission

The power, mass and size budget for each mission is given in Table 4.

**Table 4. Power, mass and size budget of Horyu-V missions**

	Power budget		Mass Budget	Size Budget [mm]
	[W]			
	Charge Mode	Discharge Mode	[g]	
<b>Discharge</b>	41.37		2,835	571×300×45
<b>Charging</b>	5.33	5.71	3,591	60×30
<b>High Voltage Solar Array</b>	5.72		478	122×327
<b>Debris Sensor</b>	4		800	1,600×1,300×0.1
<b>Electron-Emitting Film</b>	0.39	0.58	106	160×160
<b>TOTAL Missions</b>	<b>56.81</b>	<b>57.38</b>	<b>7,810</b>	<b>1,600×2,117×45</b>

#### 4.7. Additional mission: Super-capacitor technology demonstration

This mission shall demonstrate the storage attributes of super-capacitor in space from ground simulation of space environment to application in orbit. The interest on super-capacitor is gaining so much momentum due to its nearness in attaining these desired properties such as quick charging rate, high power densities and safety. In understanding the performance of the lithium-ion capacitor (LiC), we shall look at the characteristics of the lithium-ion battery (LiB) on one hand and the electric double layer capacitor (EDLC) on the other hand. LiB is composed of graphite as the negative electrode and the layered metal oxide lithium serves as the positive electrode. During charging of LiB, there are movements of the lithium-ions from the electrode (positive side) to the negative electrode. The problem with LiB is the thermal runaway and the low power density due to chemical reaction involved in charging/discharging. For the case of EDLC there is desorption and adsorption of charged ions across the double layer that are formed at the electrodes; this translates to high capacitance in comparison to the normal capacitors. The EDLC has opposite characteristics in comparison with the LiB; it has lesser voltage but higher life cycle and power density since it does not undergo chemical reaction. The merger of the attributes of LiB and EDLC results in LiC with a higher voltage compared to EDLC; hence, higher energy density (the amount of electrical energy stored per unit volume). This value is almost triple of that of EDLC of same weight. By implication this translates to higher power density (electrical energy output per unit time) and more life cycles. A typical LiC uses an activated carbon in their positive electrodes. The sorption (adsorption and desorption) of ions through thin double layer capacitor on the surface of the active carbon results in storage of energy as capacitance this infers the charge adsorption capacity hence the negative electrodes of the lithium-ion uses layered graphite and store electrical energy through adsorption of lithium-ions into the layers.

In this mission we demonstrate a complete EPS based on the super-capacitor as a storage unit. The PCU shall regulate the super-capacitor discharge /charge cycles. During Sun outage, the super-capacitor discharges to a dummy load for about 35.3 minutes. This is an ongoing research and more results will be revealed later.

#### 4.8. Additional mission: Field-Programmable Gate Array (FPGA) technology demonstration

The purpose of this mission is to demonstrate the adequacy of using SRAM-based FPGAs in building robust MPSoC avionics systems. The in-orbit verification of the experiment will provide a space heritage for the FPGA to be used and hence it can be adopted in future missions. The mission will test the operation of new fault tolerant technique to be used for SRAM-based FPGAs besides implementing a space-wire router based on the state-of-art space wire protocol. It will also implement a network communication layer based on the IPV6 protocol to allow commanding future satellites from computers connected to the world-wide internet network and cross support of ground stations running the Consultative Committee for Space Data System (CCSDS) over IPV6. This will provide a 24/7 access to the satellite. As this is an ongoing research more data will be revealed later. The Architecture of the MPSoC is shown in figure 9.

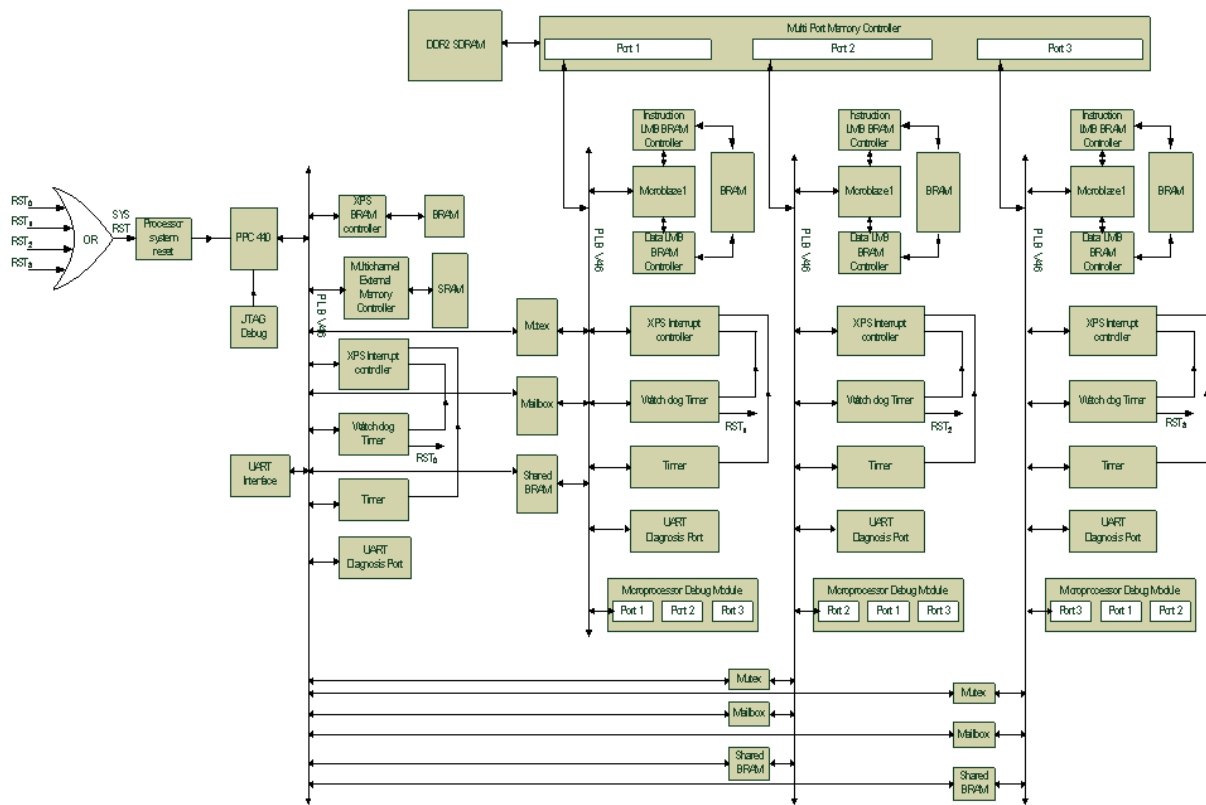

Fig. 9. FPGA Multi-Processor System-on-Chip Architecture.

### 5. AOCS and EPS Specifications

In this section we present the specifications of the HORYU-V AOC subsystem, the EPS, and the S-Band link budget.

Table 2. Attitude orientation and control subsystem specifications

Type	3-axis stabilized
Attitude control accuracy	roll, pitch: $0.0 \pm 0.5 \text{ deg} / 3.0 \text{ deg}$
Summary of attitude error	yaw: $0.0 \pm 0.1 \text{ deg} / 3.0 \text{ deg}$
<b>AOCS processor</b>	
Time delay	1 ns
<b>GPS receiver (2 instances)</b>	
Position accuracy	<10m
Velocity accuracy	<25cm/s
Update rate	>1 Hz
Operating frequency	L1 (1575.42 MHz)
<b>Rate integrating gyro assembly</b>	
Pointing performance	<10mrad
Angular momentum stability	<0.03%

<b>Magnetometer unit</b>	
Using range	$\pm 0.6$ Gauss
Noise	0.02 mGauss
Misalignment error	$0.2^\circ$
<b>Magneto-torquers (3 instances)</b>	
Magnetic moment	0.2 Am <sup>2</sup>
Linearity	$\pm 5\%$ across operating design range
Residual moment	$< 0.001$ Am <sup>2</sup>
Random vibration	15 g rms
<b>Reaction wheels (4 instances)</b>	
Momentum storage	1.1 mNms per wheel
Momentum torque	0.635 mNm per wheel
Command and TLM	RS-232

The electric power subsystem must be operational throughout the designed or slotted orbital period; the need for a robust energy storage system cannot be over-emphasized. Re-chargeable Lithium-ion-Battery (LiB) was finally selected as the means of secondary energy system for this mission after going through trade-offs with other options. This is so, in line with our design principle of reliability, low cost, commercial-off-the shelf, light weight and lessened volume. A typical lithium ion battery cell has voltage of 3.6V with power density as much as 220Wh/kg or even more. Table 5 gives the specifications for the EPS.

**Table 3. Electric power system specifications**

<b>Battery unit</b>	16 cells of 8 series 2parallels (2.15 Ah, 28V)
<b>Bus voltage</b>	28.0V
<b>Depth of discharge</b>	54.6%
<b>Beginning of life</b>	100W
<b>Generated power</b>	$> 70$ W
<b>Assigned power during eclipse</b>	70W
<b>Number of charge-discharge cycles</b>	10,728
<b>Energy density</b>	50.0 W.hr/kg

## 6. HORYU-V STRUCTURE

Several general concepts have been proposed for the structure of Horyu-V: hexahedral shape, cubic shape, triangular shape, and dome shape. Each shape were proposed with deployable components, such as solar panels and antenna, or fixed components. However, for an optimized reliability, the simpler is the better. Therefore, the cubic shape with deployable solar arrays was chosen to maximize the cross section for the de-orbiting constraint of 25 years and to increase the solar arrays area exposed to sunlight for the power demand of each payload.

Horyu-V structure uses the aluminum alloy 2024 as main material. The cube dimensions are 498×448×481 mm. Figure 10a shows an overview of Horyu-V structure in the stowed state and figure 10b in fully deployed state.

a)

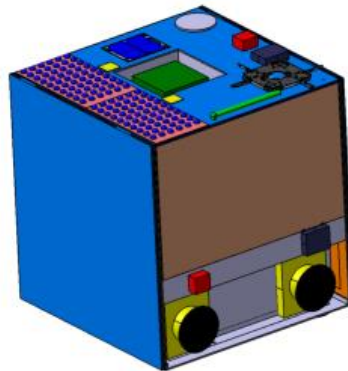

b)

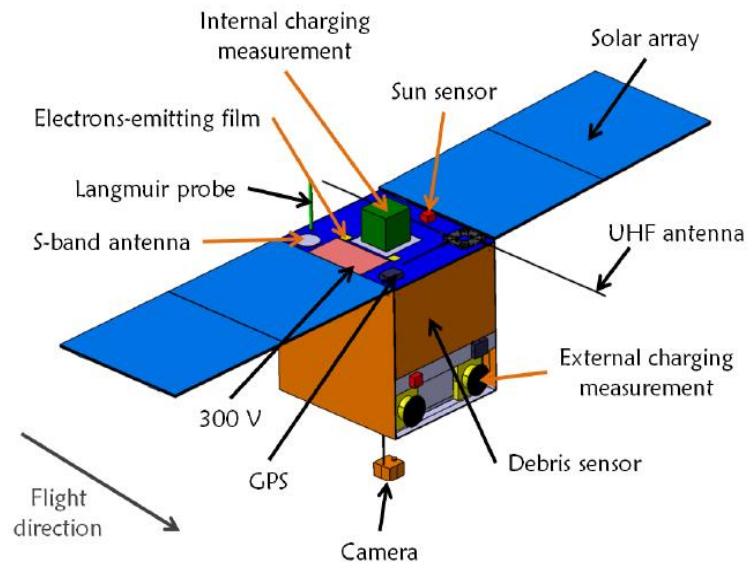

**Fig. 10. Horyu-V External Configuration. a) Stowed State. b) Deployed State**

The external structure accommodates mission sensors, such as the Langmuir probe, internal charging sensor, the camera pointing at the face the least exposed to sunlight for the discharge mission, and fixed and deployable antennas. The debris sensors, orange colored in the fig. 10a and 10b, occupy 50% of the flight direction panel and the two lateral panels. The camera deployment mechanism showed in figure 11 uses a rod deployment method. It consists of a motor controlled by the user command. The mechanical interface will be a gear mechanism which allows a translation movement. The total rod length will be decided according to the camera focal distance.

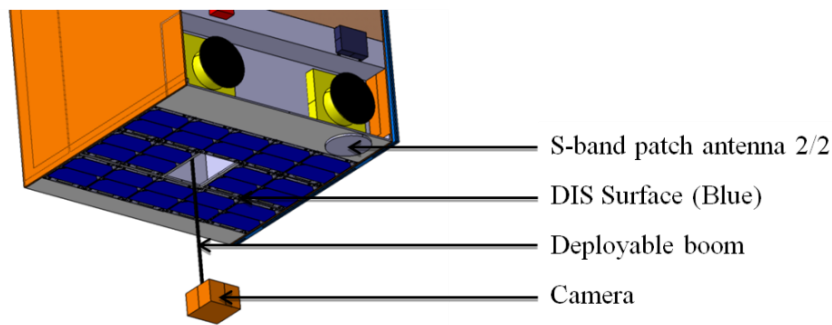

**Fig. 11. Camera Deployment Mechanism Located on the Bottom Panel (the side with the least exposure to sun).**

The inner structure showed in figure 12 is composed of 4 panels mounted as a 4.5 tatami structure. The interior of the satellite is decomposed into 4 rooms, which accommodates the basic payload, the electronic boards for controlling the different missions and some specific mission payloads. The center of the inner structure accommodates the deployment mechanisms for the camera and for the internal charging sensor. For a maximum gain of mass, the structure is composed of customized rails machined to accommodate each payload element.

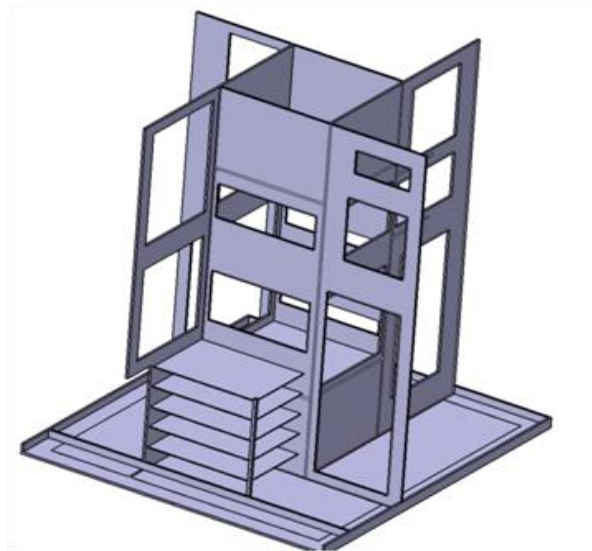

**Fig. 12. Inner structure: Isometric View**

The internal charging sensor, green colored in figures 10a and 10b, is deployable. The deployment mechanism uses a planar boom system. Keeping the sensor at the center of the 4.5 tatami structure, the deployment mechanism enables an upward translation. It could be activated by the same motor than for the camera deployment. Considering the cubic shape structure with the aforementioned configuration and considering the material density, the total structural mass, without payload, payload adaptor, and solar array is 11 kg. The total payload mass is about 29 kg. Thus, the total Horyu-V mass, with all components is 43 kg. With this configuration, the satellite structure enables 0.8 m<sup>2</sup> of solar arrays directly exposed to sunlight (deployed state). In case of panels deployment malfunction, the panels are equipped with solar arrays on both sides. Fig.13 shows Horyu-V exploded view with all inner components. For a better visibility, the colors used are deliberately chosen different than the true one.

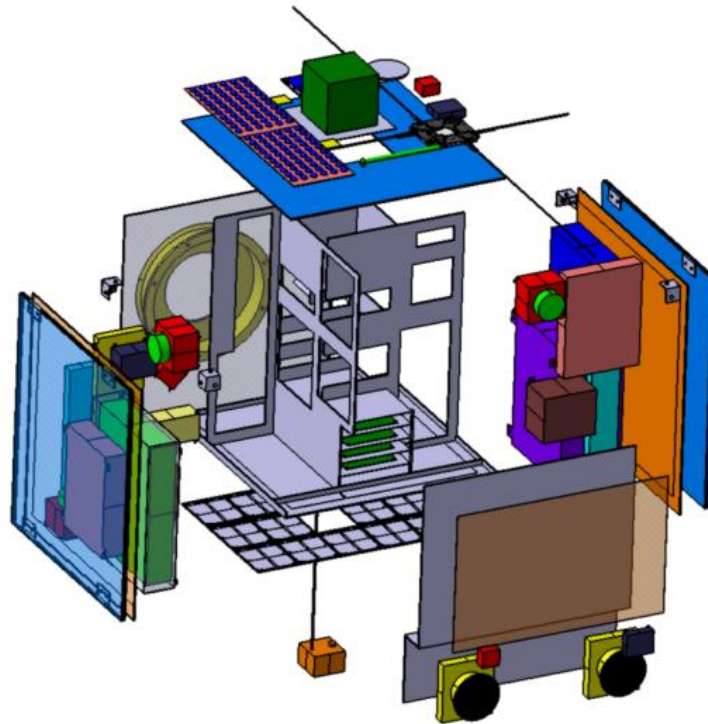

**Fig. 13. HORYU-V Exploded View.**

Several numerical simulations have been partially performed using finite element analysis software such as ANSYS or NASTRAN. The numerical analysis includes the static and quasi-static strength analysis, the vibration analysis (modal, sinusoidal, random), the shock load and the thermal load according to the specification of a typical launcher. The whole simulation phase shall finish before the upcoming critical design review. The inertia parameters have been determined to size the attitude determination and control system elements. A total deformation simulation under the maximum steady-state acceleration using ANSYS 13.0 has already been performed for a single panel. The mechanical parameters (Young modulus, density, Poisson coefficient...) have been set for the aluminum alloy 2024. The maximum displacement (about 0.03mm) is clearly negligible.

## 7. COMMUNICATION & MISSION CONTROL ARCHITECTURE

Horyu-V will have a ground control station to upload the telecommands to the satellite and receive the telemetry/mission data from it. The ground control station will handle communication with the satellite using the Consultative Committee for Space Data System (CCSDS) data communication protocol to allow for cross-support [8]. In case the station is not capable to communicate with the satellite, another station might take over and communicate with it based on a beforehand agreement. One of the protocols that might allow this cross-support function to take place is the CCSDS protocol. It is widely accepted and adopted by many satellite builders and operators. It is important to emphasize that the ground control station will communicate with the mission control center through a network interface such as a local area network. It will receive commands to be uploaded to the satellite and send telemetry/data downloaded from the satellite from/to the control station.

The mean session time is about 600 sec. During the session, the real time telemetry will first be downloaded, and then the set of telecommands will be uploaded to be executed either in real time or off-sight. The scientific data will then be downloaded and followed by the last status telemetry to ensure that satellite leaves the communication session while operating correctly. The basic communication architecture is shown in figure 14.

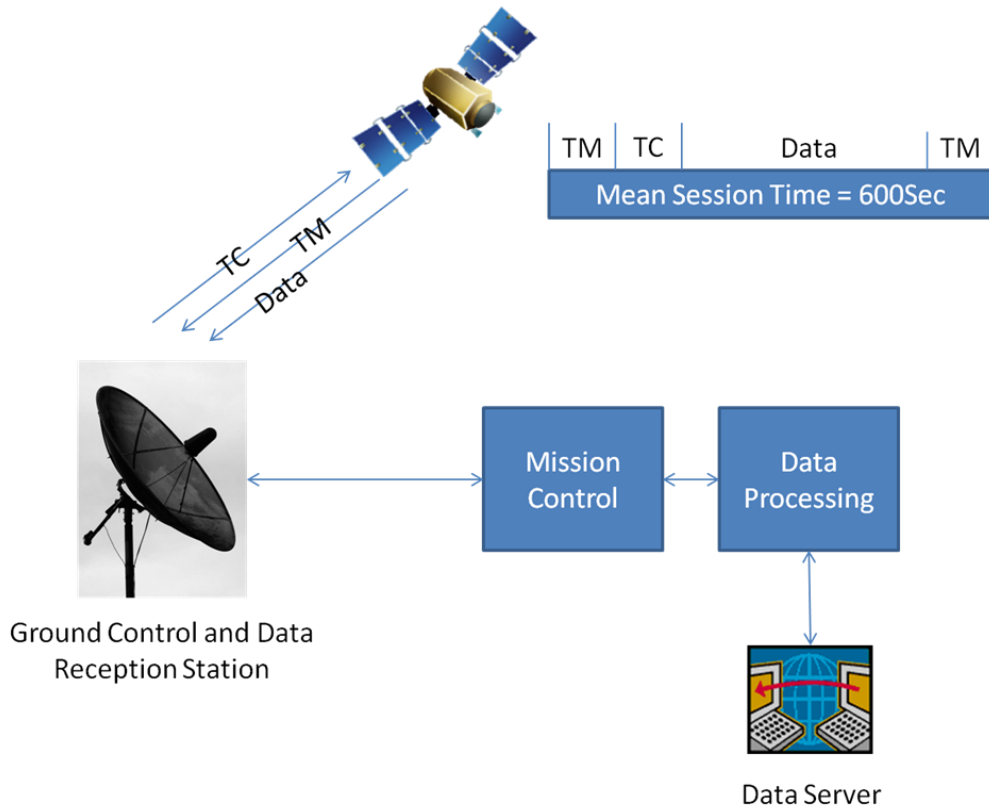

**Fig. 14. Ground Control Station Communication Architecture**

In Fig. 15, the mission control architecture is presented. The mission data server is responsible for archiving the received mission data. The in-orbit control is responsible for preparing the list of commands to be executed either during session or off-session. The in-orbit control will also generate the data arrays carrying configuration and settings parameters. The payload planning is responsible for issuing the commands that will start/end a specific mission based on estimations of adequacy to run the mission in terms of the current satellite battery charge level, appropriateness of operation conditions for the specific mission, and user requirements. The list of constraints for each mission operation should be detailed in subsequent project phases. The commands issued by the payload planning section are directly inserted by the in-orbit control section in the command stream to be uploaded to the satellite. The TM processing unit is responsible for analyzing the TM information, generating a health-report about the satellite operation, and it should be able to perform analysis both in real-time and off-line. The TM processing unit communicates with a more detailed analysis unit for handling the analysis of the satellite attitude determination and control subsystem performance. The satellite required orientation is simulated and compared to the real satellite orientation that would take place in orbit. Correction coefficients for the control algorithm gains are applied to achieve the required control portfolio. The ballistics and navigation unit is responsible for updating the satellite TLE based on running its orbit propagator and feeding accurate orbital position through range, range-rate, and GPS measurements. TLE can be updated through the North American Aerospace Defense Command (NORAD) website [10].



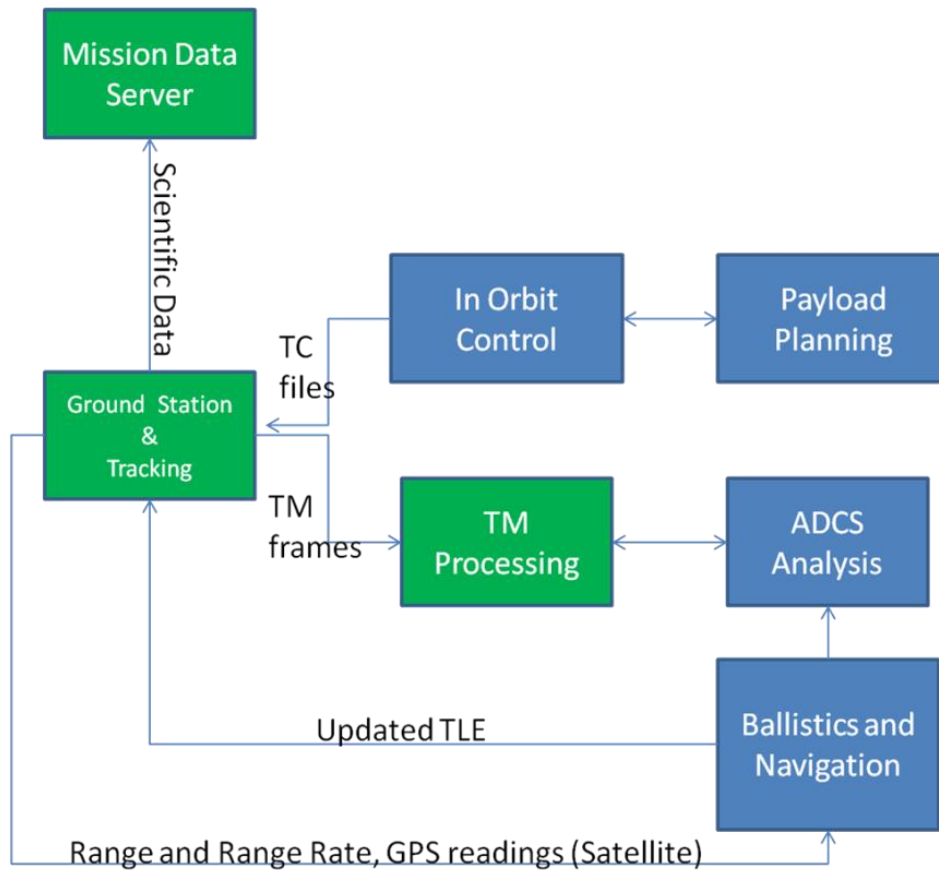

**Fig. 15. Mission Control Architecture**

## 8. CONCLUSION

The HORYU-V, the Space Environment Explorer design concept was introduced in this paper. The HORYU-V design is based on the principle of low cost and robustness without jeopardizing quality. Some components to be used are space proven and the Commercial-Off-The-Shelf (COTS) components to be used shall be equipped with all the mitigations and control for space environment tolerance. All the components shall undergo the standard testing so as to meet the performance of the system design which shall further be enhanced at the preliminary design review and critical design review levels. Although the Horyu-V mainly targets the Japanese launchers for issues of compatibility and cost, it would be tested to cover wide range of other launcher requirements to increase its launch opportunities as much as possible.

## ACKNOWLEDGMENTS

All the Horyu-V members would like to thank Prof. Kenichi Asami, Prof. Kazuhiro TOYODA, Prof. Minoru IWATA and Prof. Yasuhiro AKAHOSHI for their help regarding the satellite main missions definitions. Also we do gratefully appreciate the advices given by Dr. Hirokazu MASUI, Dr. Tatsuo SHIMIZU and Dr. Arifur KHAN. HORYU-V is an extra Curricula activity that is being done within the Program of Nano-Satellite Technologies (PNST) sponsored by Kyushu Institute of Technology and the United Nations Office for Outer Space Affairs (UNOOSA). We would like to thank all the organizers and administrative staff who work for making the PNST so helpful for students. We dedicate a special thanks to Dr. Werner Balogh from the UNOOSA for his support and efforts in the PNST and the Basic Space Technology Initiative (BSTI) at UNOOSA.

## REFERENCES

- [1] Online SPENVIS package, <http://www.spervis.oma.be>
- [2] Toyoda K., Cho M. and Noda R. (2013). Discharge propagation in normal potential gradient on spacecraft, Proc. of the International Symposium on Space Technology and Science, 2013-r-40.
- [3] D.L. Glaser, J.S. Halekas, P. Turin, D.W. Curtis, D.E. Larson, S.E. McBride and R.P. Lin, 2009, STEIN (Supra Thermal Electrons, Ions and Neutrals), a New Particle Detection Instrument for Space Weather Research with CubeSats, 23rd Annual AIAA/USU, Conference on Small Satellites.
- [4] K.A. Ryden, C.S. Dyer, P.A. Morris, R.A. Haine and S. Jason, 2004, The Merlin space weather monitor and its planned flight on the Galileo system tested satellite (GSTB-V2/A), Proc. IAC.
- [5] Hosoda, S.; Okumura, T.; Jeong-Ho Kim; Toyoda, K.; Mengu Cho, "Development of 400 V Solar Array Technology for Low Earth Orbit Plasma Environment," Plasma Science, IEEE Transactions on , vol.34, no.5, pp.1986,1996, Oct. 2006.
- [6] M. Cho,T. Okumura,M. Iwata,K. Toyoda,H. Igawa,Y. Fujiwara,S. Hatta,T. Satou,T. Fujita, "Development of Electron-emitting Film for Spacecraft Charging Mitigation: Observation, Endurance and Simulations," 47th AIAA Aerospace Science Meeting, Jan 2009.
- [7] Khan, A.R.; Sumida, T.; Iwata, M.; Toyoda, K.; Mengu Cho; Fujita, T., "Environment Exposure Tests of Electron-Emitting Film for Spacecraft Charging Mitigation," Plasma Science, IEEE Transactions on , vol.40, no.2, pp.380,387, Feb. 2012.
- [8] European Cooperation for Space Standardization, 31 July 2008, Space engineering – Ground systems and operations, ECSS-E-ST-70C
- [9] European Cooperation for Space Standardization, 31 July 2008, Space project management – Cost and schedule management, ECSS-M-ST-60C
- [10] North American Aerospace Defense Command website, <http://www.norad.mil>